



**IEEE Standard for
Information technology—
Telecommunications and information
exchange between systems—
Local and metropolitan area networks—
Specific requirements**

**Part 15.4: Wireless Medium Access Control
(MAC) and Physical Layer (PHY)
Specifications for Low-Rate Wireless
Personal Area Networks (WPANs)**

**Amendment 3: Alternative Physical Layer Extension
to support the Japanese 950 MHz bands**

IEEE Computer Society

Sponsored by the
LAN/MAN Standards Committee

IEEE
3 Park Avenue
New York, NY 10016-5997, USA
17 April 2009

IEEE Std 802.15.4d™-2009
(Amendment to
IEEE Std 802.15.4™-2006)

802.15.4d™

IEEE Std 802.15.4d™-2009

(Amendment to
IEEE Std 802.15.4™-2006)

**IEEE Standard for
Information technology—
Telecommunications and information
exchange between systems—
Local and metropolitan area networks—
Specific requirements**

**Part 15.4: Wireless Medium Access Control
(MAC) and Physical Layer (PHY)
Specifications for Low-Rate Wireless
Personal Area Networks (WPANs)**

**Amendment 3: Alternative Physical Layer Extension
to support the Japanese 950 MHz bands**

Sponsor

**LAN/MAN Standards Committee
of the
IEEE Computer Society**

Approved 19 March 2009

IEEE-SA Standards Board

Abstract: This amendment to IEEE Std 802.15.4-2006 is limited to defining a new PHY and such changes to the MAC as are necessary to support a new frequency allocation (950 MHz) in Japan. The amendment shall completely follow the new technical conditions described in Japanese ministerial ordinance. The amendment shall coexist with passive tag systems in the band.

Keywords: ad hoc network, low data rate, low power, LR-WPAN, mobility, PAN, personal area network, radio frequency, RF, short range, wireless, wireless personal area network, WPAN

The Institute of Electrical and Electronics Engineers, Inc.
3 Park Avenue, New York, NY 10016-5997, USA

Copyright © 2009 by the Institute of Electrical and Electronics Engineers, Inc.
All rights reserved. Published 17 April 2009. Printed in the United States of America.

IEEE and 802 are registered trademarks in the U.S. Patent & Trademark Office, owned by The Institute of Electrical and Electronics Engineers, Incorporated.

The *Bluetooth* word mark, figure mark, and combination mark are all trademarks that are owned by the Bluetooth SIG.

PDF: ISBN 978-0-7381-5915-7 STD95912
Print: ISBN 978-0-7381-5916-4 STDPD95912

No part of this publication may be reproduced in any form, in an electronic retrieval system or otherwise, without the prior written permission of the publisher.

IEEE Standards documents are developed within the IEEE Societies and the Standards Coordinating Committees of the IEEE Standards Association (IEEE-SA) Standards Board. The IEEE develops its standards through a consensus development process, approved by the American National Standards Institute, which brings together volunteers representing varied viewpoints and interests to achieve the final product. Volunteers are not necessarily members of the Institute and serve without compensation. While the IEEE administers the process and establishes rules to promote fairness in the consensus development process, the IEEE does not independently evaluate, test, or verify the accuracy of any of the information or the soundness of any judgments contained in its standards.

Use of an IEEE Standard is wholly voluntary. The IEEE disclaims liability for any personal injury, property or other damage, of any nature whatsoever, whether special, indirect, consequential, or compensatory, directly or indirectly resulting from the publication, use of, or reliance upon this, or any other IEEE Standard document.

The IEEE does not warrant or represent the accuracy or content of the material contained herein, and expressly disclaims any express or implied warranty, including any implied warranty of merchantability or fitness for a specific purpose, or that the use of the material contained herein is free from patent infringement. IEEE Standards documents are supplied **“AS IS.”**

The existence of an IEEE Standard does not imply that there are no other ways to produce, test, measure, purchase, market, or provide other goods and services related to the scope of the IEEE Standard. Furthermore, the viewpoint expressed at the time a standard is approved and issued is subject to change brought about through developments in the state of the art and comments received from users of the standard. Every IEEE Standard is subjected to review at least every five years for revision or reaffirmation. When a document is more than five years old and has not been reaffirmed, it is reasonable to conclude that its contents, although still of some value, do not wholly reflect the present state of the art. Users are cautioned to check to determine that they have the latest edition of any IEEE Standard.

In publishing and making this document available, the IEEE is not suggesting or rendering professional or other services for, or on behalf of, any person or entity. Nor is the IEEE undertaking to perform any duty owed by any other person or entity to another. Any person utilizing this, and any other IEEE Standards document, should rely upon his or her independent judgment in the exercise of reasonable care in any given circumstances or, as appropriate, seek the advice of a competent professional in determining the appropriateness of a given IEEE standard.

Interpretations: Occasionally questions may arise regarding the meaning of portions of standards as they relate to specific applications. When the need for interpretations is brought to the attention of IEEE, the Institute will initiate action to prepare appropriate responses. Since IEEE Standards represent a consensus of concerned interests, it is important to ensure that any interpretation has also received the concurrence of a balance of interests. For this reason, IEEE and the members of its societies and Standards Coordinating Committees are not able to provide an instant response to interpretation requests except in those cases where the matter has previously received formal consideration. A statement, written or oral, that is not processed in accordance with the IEEE-SA Standards Board Operations Manual shall not be considered the official position of IEEE or any of its committees and shall not be considered to be, nor be relied upon as, a formal interpretation of the IEEE. At lectures, symposia, seminars, or educational courses, an individual presenting information on IEEE standards shall make it clear that his or her views should be considered the personal views of that individual rather than the formal position, explanation, or interpretation of the IEEE.

Comments for revision of IEEE Standards are welcome from any interested party, regardless of membership affiliation with IEEE. Suggestions for changes in documents should be in the form of a proposed change of text, together with appropriate supporting comments. Comments on standards and requests for interpretations should be submitted to the following address:

Secretary, IEEE-SA Standards Board
445 Hoes Lane
Piscataway, NJ 08854
USA

Authorization to photocopy portions of any individual standard for internal or personal use is granted by The Institute of Electrical and Electronics Engineers, Inc., provided that the appropriate fee is paid to Copyright Clearance Center. To arrange for payment of licensing fee, please contact Copyright Clearance Center, Customer Service, 222 Rosewood Drive, Danvers, MA 01923 USA; +1 978 750 8400. Permission to photocopy portions of any individual standard for educational classroom use can also be obtained through the Copyright Clearance Center.

Introduction

This introduction is not part of IEEE Std 802.15.4d-2009, IEEE Standard for Information technology—Telecommunications and information exchange between systems—Local and metropolitan area networks—Specific requirements—Part 15.4: Wireless LAN Medium Access Control (MAC) and Physical Layer (PHY) Specifications for Low-Rate Wireless Personal Area Networks (LR-WPANS)—Amendment 3: Alternative Physical Layer Extension to support the Japanese 950 MHz bands.

This amendment specifies alternate PHYs in addition to those of IEEE Std 802.15.4-2006, IEEE Std 802.15.4aTM-2007, and IEEE Std 802.15.4cTM-2009. These alternate PHYs are specified for the Japanese 950 MHz band.

Notice to users

Laws and regulations

Users of these documents should consult all applicable laws and regulations. Compliance with the provisions of this standard does not imply compliance to any applicable regulatory requirements. Implementers of the standard are responsible for observing or referring to the applicable regulatory requirements. IEEE does not, by the publication of its standards, intend to urge action that is not in compliance with applicable laws, and these documents may not be construed as doing so.

Copyrights

This document is copyrighted by the IEEE. It is made available for a wide variety of both public and private uses. These include both use, by reference, in laws and regulations, and use in private self-regulation, standardization, and the promotion of engineering practices and methods. By making this document available for use and adoption by public authorities and private users, the IEEE does not waive any rights in copyright to this document.

Updating of IEEE documents

Users of IEEE standards should be aware that these documents may be superseded at any time by the issuance of new editions or may be amended from time to time through the issuance of amendments, corrigenda, or errata. An official IEEE document at any point in time consists of the current edition of the document together with any amendments, corrigenda, or errata then in effect. In order to determine whether a given document is the current edition and whether it has been amended through the issuance of amendments, corrigenda, or errata, visit the IEEE Standards Association website at <http://ieeexplore.ieee.org/xpl/standards.jsp>, or contact the IEEE at the address listed previously.

For more information about the IEEE Standards Association or the IEEE standards development process, visit the IEEE-SA website at <http://standards.ieee.org>.

Errata

Errata, if any, for this and all other standards can be accessed at the following URL: <http://standards.ieee.org/reading/ieee/updates/errata/index.html>. Users are encouraged to check this URL for errata periodically.

Interpretations

Current interpretations can be accessed at the following URL: <http://standards.ieee.org/reading/ieee/interp/index.html>.

Patents

Attention is called to the possibility that implementation of this amendment may require use of subject matter covered by patent rights. By publication of this amendment, no position is taken with respect to the existence or validity of any patent rights in connection therewith. The IEEE is not responsible for identifying Essential Patent Claims for which a license may be required, for conducting inquiries into the legal validity or scope of Patents Claims or determining whether any licensing terms or conditions provided in connection with submission of a Letter of Assurance, if any, or in any licensing agreements are reasonable or non-discriminatory. Users of this amendment are expressly advised that determination of the validity of any patent rights, and the risk of infringement of such rights, is entirely their own responsibility. Further information may be obtained from the IEEE Standards Association.

Participants

At the time this standard was sent to sponsor ballot, the IEEE P802.15™ Working Group had the following voting members:

Robert F. Heile, *Chair*
Rick Alfvén, *Vice Chair*
Patrick W. Kinney, *Vice-Chair, Secretary*
James P. K. Gilb, *Technical Editor*
John R. Barr, *Treasurer*

Reed Fisher, *Task Group 3c Chair*
Clinton C Powell, *Task Group 4c Chair*
Patrick W. Kinney, *Task Group 4e Chair*
Myung Lee, *Task Group 5 Chair*
Arthur Astrin, *Task Group 6 Chair*

Philip E. Beecher, *Task Group 4d Chair*
Shigeru Fukunaga, *Task Group 4d Vice Chair, Secretary*
Kiyoshi Fukui, *Task Group 4d Editor-in-Chief*
Yasutaka Kawamoto, *Task Group 4d Assistant Secretary*
Jay Bain, *Contributing Editor/Editorial Advisor*
Michael Schmidt, *Contributing Editor*
Shusaku Shimada, *Contributing Editor*

Taehan Bae
Gal Basson
Tuncer Baykas
Bruce Bosco
Andre Bourdoux
Pat Carson
Eduardo Casas
Philippe Chambelin
Kuor-Hsin Chang
Chang-Soon Choi
Carlos Cordeiro
Alexey Davydov
Paul Dixon
Kai Dombrowski
John Dorsey
Bas Driesen
Amal Ekbal
Yossi Erlich
Robert Fanfelle
John Farserotu
Yoshitsugu Fujita
Ryuhei Funada
Uhland Goebel
Giriraj Goyal
Eckhard Grass
Mark Grodzinsky
Vivek Gupta
Robert Hall
Christopher J. Hansen
Shinsuke Hara
Hiroshi Harada
Seockdeock Hong
Tian-Wei Huang
Ichirou Ida
Hideto Ikeda
Tetsushi Ikegami
Akio Iso

Beomjin Jeon
Young-Ae Jeon
Seong-Soon Joo
Chol Su Kang
Tae-Gyu Kang
Yasunao Katayama
Shuzo Kato
Stuart J. Kerry
Jaehwa Kim
Jae-Hyon Kim
Jinkyong Kim
Kihong Kim
Kyeongpyo Kim
Seong Kim
Yongsun Kim
Ryota Kimura
Kursat Kimyacioglu
Ryuji Kohno
Fumihide Kojima
Edwin Kwon
Hyoungjin Kwon
Ismail Lakkis
John Lampe
Zhou Lan
Jae Lee
Jeong Lee
Seonghee Lee
Taehoon Lee
Wooyong Lee
Daniel Lewis
Huan-Bang Li
Sheung Li
Yong Liu
Alexander Maltsev
Abbie Mathew
Taisuke Matsumoto
Michael Mcinnis

Michael McLaughlin
Dino Miniutti
Rajendra Moorti
Jorge Myszné
Yukimasa Nagai
Ken Naganuma
Chiu Ngo
Paul Nikolich
Yoshinori Nishiguchi
Hiroyo Ogawa
Jisung Oh
Laurent Ouvry
Pascal Pagani
Tae Rim Park
Maulin Patel
Stephane Pinel
Stephen Pope
Chang Woo Pyo
Xiangping Qin
Ivan Reede
Richard Roberts
Ali Sadri
Katsuyoshi Sato
Hirokazu Sawada
Kamran Sayrafian
Jean Schwoerer
Huai-Rong Shao
Stephen Shellhammer
Yukihiro Shimakata
Chang Sub Shin
Michael Sim
Harkirat Singh
Carl Stevenson
Paul Strauch
Chin Sum
Kazuaki Takahashi
Kenichi Takizawa

Arnaud Tonnerre
Ichihiko Toyoda
Jason Trachewsky
Solomon Trainin
Alberto Valdes Garcia
Magnus Wiklund

Gerald Wineinger
Ludwig Winkel
Eun Tae Won
Jongeeun Won
Pengfei Xia
Kamya Yazdandoost

James Yee
Kaoru Yokoo
Su Yong
Zhan Yu
Bin Zhen
Chunhui Zhu

Major contributions were received from the following individuals:

Kuor-Hsin Chang
Paul Gorday
Patrick Kinney

Klaus Meyer
Frank Poegel
Clinton Powell
Benjamin Rolfe

Hendricus De Ruijter
Michael Schmidt
Stephen J. Shellhammer

The following members of the individual balloting committee voted on this standard. Balloters may have voted for approval, disapproval, or abstention.

Butch Anton
Jay Bain
Philip Beecher
Gennaro Boggia
Vern Brethour
William Byrd
Jing Cao
Juan Carreon
Kuor-Hsin Chang
Aik Chindapol
Keith Chow
Charles Cook
Russell Dietz
Thomas Dineen
Petar Djukic
Sourav Dutta
Paul Eastman
Kiyoshi Fukui
Shigeru Fukunaga
Devon Gayle
Theodore Georgantas
James Gilb
Randall Groves

Jose A. Gutierrez
C. Guy
Rainer Hach
Robert F. Heile
Marco Hernandez
Karl Heubaum
Tetsushi Ikegami
Atsushi Ito
Raj Jain
Shinkyō Kaku
Assaf Kasher
Stuart J. Kerry
Chad Kiger
Yongbum Kim
Patrick Kinney
Myung Lee
Jan-Ray Liao
Arthur Light
William Lumpkins
Michael Mcinnis
Klaus Meyer
Marco Naeve
Hiroyuki Nakase
Michael S. Newman

John Notor
Chris Osterloh
Eldad Perahia
Frank Poegel
Clinton Powell
Jayaram Ramasastry
Robert Robinson
Benjamin Rolfe
Randall Safier
Bartien Sayogo
Michael Schmidt
Shusaku Shimada
Gil Shultz
Amjad Soomro
Thomas Starai
Rene Struik
Walter Struppler
Mark Sturza
Dmitri Varsanofiev
Srinivasa Vemuru
Udo Walter
Stanley Wang
Andreas Wolf
Oren Yuen

When the IEEE-SA Standards Board approved this standard on 19 March 2009, it had the following membership:

Robert M. Grow, *Chair*

Steve M. Mills, *Past Chair*

Judith Gorman, *Secretary*

John Barr
Karen Bartleson
Victor Berman
Ted Burse
Richard DeBlasio
Andy Drozd
Mark Epstein

Alexander Gelman
Jim Hughes
Rich Hulet
Young Kyun Kim
Joseph L. Koepfinger*
John Kulick
David Law
Ted Olsen

Glenn Parsons
Ron Petersen
Chuck Powers
Thomas Prevost
Narayanan Ramachandran
Jon Rosdahl
Sam Sciacca

*Member Emeritus

Also included are the following nonvoting IEEE-SA Standards Board liaisons:

Satish K. Aggarwal, *NRC Representative*
Michael Janezic, *NIST Representative*
Howard Wolfman, *TAB Representative*

Don Messina
IEEE Standards Program Manager, Document Development

Michael D. Kipness
IEEE Standards Program Manager, Technical Program Development

Contents

4.	Acronyms and abbreviations	1
5.	General description	2
5.1	Introduction.....	2
5.4	Architecture	2
5.4.1	Physical layer (PHY).....	2
6.	PHY specification	3
6.1	General requirements and definitions	3
6.1.1	Operating frequency range.....	3
6.1.2	Channel assignments.....	4
6.1.3	Minimum LIFS and SIFS periods.....	5
6.3	PPDU format.....	5
6.3.1	Preamble field	5
6.3.2	SFD field.....	6
6.4	PHY constants and PIB attributes.....	7
6.4.2	PHY PIB attributes	7
6.6	868/915/950 MHz band binary phase-shift keying (BPSK) PHY specifications	7
6.6.1	868/915/950 MHz band data rates	7
6.6.2	Modulation and spreading	7
6.6.3	868/915/950 MHz band radio specification.....	7
6.6b	950 MHz band Gaussian frequency-shift keying (GFSK) PHY specifications.....	9
6.6b.1	950 MHz band data rates	9
6.6b.2	Modulation and spreading	9
6.6b.3	950 MHz band radio specification for the GFSK PHY	11
6.9	General radio specifications.....	12
6.9.9	Clear channel assessment (CCA).....	12
7.	MAC sublayer specification	13
7.1	MAC sublayer service specification	13
7.1.1	MAC data service	13
7.4	MAC constants and PIB attributes.....	13
7.4.2	MAC PIB attributes	13
7.5	MAC functional description	14
7.5.1	Channel access	14
7.5.2	Starting and maintaining PANs	15
	Annex D (normative) Protocol implementation conformance statement (PICS) proforma	17
	Annex E (informative) Coexistence with other IEEE standards and proposed standards	19
	Annex F (informative) Regulatory requirements.....	21
	Annex G (informative) Bibliography	25
	Annex K (informative) Considerations for 950 MHz band.....	27

**IEEE Standard for
Information technology—
Telecommunications and information
exchange between systems—
Local and metropolitan area networks—
Specific requirements**

**Part 15.4: Wireless Medium Access Control
(MAC) and Physical Layer (PHY)
Specifications for Low-Rate Wireless
Personal Area Networks (WPANs)**

**Amendment 3: Alternative Physical Layer Extension to
support the Japanese 950 MHz band**

IMPORTANT NOTICE: This standard is not intended to assure safety, security, health, or environmental protection in all circumstances. Implementers of the standard are responsible for determining appropriate safety, security, environmental, and health practices or regulatory requirements.

This IEEE document is made available for use subject to important notices and legal disclaimers. These notices and disclaimers appear in all publications containing this document and may be found under the heading “Important Notice” or “Important Notices and Disclaimers Concerning IEEE Documents.” They can also be obtained on request from IEEE or viewed at <http://standards.ieee.org/IPR/disclaimers.html>.

EDITORIAL NOTE—The editing instructions contained in this amendment define how to merge the material contained therein into the existing base standard and its amendments to form the comprehensive standard.

The editing instructions are shown in *bold italic*. Four editing instructions are used: change, delete, insert, and replace. **Change** is used to make corrections in existing text or tables. The editing instruction specifies the location of the change and describes what is being changed by using ~~strike through~~ (to remove old material) and underline (to add new material). **Delete** removes existing material. **Insert** adds new material without disturbing the existing material. Insertions may require renumbering. If so, renumbering instructions are given in the editing instruction. **Replace** is used to make changes in figures or equations by removing the existing figure or equation and replacing it with a new one. Editorial notes will not be carried over into future editions because the changes will be incorporated into the base standard

4. Acronyms and abbreviations

Insert the following acronyms in alphabetical order:

GFSK	Gaussian frequency-shift keying
LBT	listen before talk

5. General description

5.1 Introduction

Change the following item of the dashed list in 5.1 as shown:

- 16 channels in the 2450 MHz band, 30 channels in the 915 MHz band, 3 channels in the 868 MHz band, 14 overlapping chirp spread spectrum (CSS) channels in the 2450 MHz band, 16 channels in three UWB bands (500 MHz and 3.1 GHz to 10.6 GHz), ~~and~~ 8 channels in the 780 MHz band and 22 channels in 950 MHz band.

5.4 Architecture

5.4.1 Physical layer (PHY)

Insert a new dashed list item at the end of the third paragraph dashed list in 5.4.1 as shown:

- 950–956 MHz (Japan, as described in Annex K)

6. PHY specification

6.1 General requirements and definitions

Change first sentence of fourth paragraph in 6.1 as follows:

The standard specifies the following ~~four~~ PHYs:

Add the following items to the second dashed list:

- A 950 MHz direct sequence spread spectrum (DSSS) PHY employing binary phase-shift keying (BPSK) modulation
- A 950 MHz PHY employing Gaussian frequency-shift keying (GFSK) modulation

Insert the following paragraph at the end of 6.1:

In further additions to the PHYs supported in IEEE Std 802.15.4-2006, and IEEE Std 802.15.4a-2007, and IEEE Std 802.15.4c-2009, two additional PHYs have been added. They are BPSK and GFSK PHYs operating in the Japanese 950 MHz band.

6.1.1 Operating frequency range

Insert new rows to Table 1 (the entire table is not shown) as indicated:

Table 1—Frequency bands and data rates

PHY (MHz)	Frequency band (MHz)	Spreading parameters		Data parameters		
		Chip rate (kchip/s)	Modulation	Bit rate (kb/s)	Symbol rate (ksymbol/s)	Symbols
950 ^a	950–956	—	GFSK	100	100	Binary
950 ^a	950–956	300	BPSK	20	20	Binary
2400	2400–2483.5	2000	O-QPSK	250	62.5	16-ary Orthogonal

^aFor the 950 MHz PHYs, at least one of the two PHYs specified shall be implemented.

Change the list of Japanese regulatory documents as indicated:

Japan:

- Approval standards: Association of Radio Industries and Businesses (ARIB)
- Document: ARIB STD-T66 [B22] and ARIB STD-T96 [B22a]
- Approval authority: Ministry of Public Management, Home Affairs, Posts and Telecommunications (MPHPT)

6.1.2 Channel assignments

Insert the following new subclause after 6.1.2.1c:

6.1.2.1d Channel numbering for 950 MHz PHYs

For channel page 6, 22 channels numbered 0 to 21 are available across 950 MHz band to support the 950 MHz PHY. Channels 0–7 are for 1 mW BPSK, 8–9 are for 10 mW BPSK and 10–21 are for GFSK. The center frequency of these channels is defined as follows:

$$F_c = 951.2 + 0.6 k \text{ in megahertz, for } k = 0, \dots, 7$$

$$F_c = 954.4 + 0.2 (k - 8) \text{ in megahertz, for } k = 8, 9$$

$$F_c = 951.1 + 0.4 (k - 10) \text{ in megahertz, for } k = 10, \dots, 21$$

where k is the channel number.

For each PHY supported, a compliant device shall support all channels allowed by regulations for the region in which the device operates, except for channels 14 and 17, which are optional.

6.1.2.2 Channel pages

Change Table 2 (the entire table is not shown) as indicated:.

Table 2—Channel page and channel number

Channel page (decimal)	Channel page (binary) (b31,b30,b29,b28,b27)	Channel number(s) (decimal)	Channel number description
6	00110	0–9	Channels 0 to 9 are in 950 MHz band using BPSK
		10–21	Channels 10 to 21 are in 950 MHz band using GFSK
67–31	00111–11111	Reserved	Reserved

6.1.3 Minimum LIFS and SIFS periods

Change Table 3 (the entire table is not shown) as indicated:.

Table 3—Minimum LIFS and SIFS period

PHY	macMinLIFSPeriod	macMinSIFSPeriod	Units
950–956 MHz GFSK	40	12	Symbols
950–956 MHz BPSK	40	12	Symbols
2400–24083.5 MHz BPSK	40	12	Symbols

6.3 PPDU format

Change 6.3.1 and Table 19 as indicated:

6.3.1 Preamble field

Preamble lengths for ASK are expressed in equivalent octet times as the preamble for ASK is defined using

Table 19—Preamble field length

PHY	Length		Duration (uS)
868–868.6 MHz BPSK	4 octets	32 symbols	1600
902–928 MHz BPSK	4 octets	32 symbols	800
<u>950–956 MHz BPSK</u>	<u>4 octets</u>	<u>32 symbols</u>	<u>1600</u>
868–868.6 MHz ASK	5 octets	2 symbols	160
902–928 MHz ASK	3.75 octets	6 symbols	120
868–868.6 MHz O-QPSK	4 octets	8 symbols	320
902–928 MHz O-QPSK	4 octets	8 symbols	128
2400–2483.5 MHz O-QPSK	4 octets	8 symbols	128
<u>950–956 MHz GFSK</u>	<u>4 octets</u>	<u>32 symbols</u>	<u>320</u>

a special symbol. For all PHYs except the ASK, CSS, ~~and~~ UWB and 950 MHz GFSK PHYs, the bits in the Preamble field shall be binary zeros. The ASK preamble format is described in 6.7.4.1. The bits in the preamble field for the 950 MHz GFSK PHY shall be "01010101010101010101010101010101."

6.3.2 SFD field

Change Table 20 (the entire table is not shown) as indicated:

Table 20—SFD field length

PHY	Length	
868–868.6 MHz BPSK	1 octet	8 symbols
902–928 MHz BPSK	1 octet	8 symbols
<u>950–956 MHz BPSK</u>	<u>1 octet</u>	<u>8 symbols</u>
868–868.6 MHz ASK	2.5 octets	1 symbol
902–928 MHz ASK	0.625 octets	1 symbol
868–868.6 MHz O-QPSK	1 octet	2 symbols
902–928 MHz O-QPSK	1 octet	2 symbols
2400–2483.5 MHz O-QPSK	1 octet	2 symbols
<u>950–956 MHz GFSK</u>	<u>1 octet</u>	<u>8 symbols</u>

6.4 PHY constants and PIB attributes

6.4.2 PHY PIB attributes

Insert the following new row at the end of Table 23:

Table 23—PHY PIB attributes

Attribute	Identifier	Type	Range	Description
<u>phyCCADuration</u>	<u>0x21</u>	<u>Integer</u>	<u>8–1000</u>	<u>The duration for the CCA, specified in symbols. This attribute shall only be implemented in combination with the 950 MHz band PHY.</u>

Change subclause 6.6 as indicated:

6.6 868/915/950 MHz band binary phase-shift keying (BPSK) PHY specifications

6.6.1 868/915/950 MHz band data rates

The data rate of the 868/915/950 MHz band BPSK PHY shall be 20 kb/s when operating in the 868/950 MHz band and 40 kb/s when operating in the 915 MHz band.

6.6.2 Modulation and spreading

The 868/915/950 MHz BPSK PHY shall employ direct sequence spread spectrum (DSSS) with BPSK used for chip modulation and differential encoding used for data symbol encoding.

6.6.2.1 Reference modulator diagram

The functional block diagram in Figure 21 is provided as a reference for specifying the 868/915/950 MHz band BPSK PHY modulation and spreading functions. The number in each block refers to the subclause that describes that function. Each bit in the PPDU shall be processed through the differential encoding, bit-to-chip mapping and modulation functions in octet-wise order, beginning with the Preamble field and ending with the last octet of the PSDU. Within each octet, the LSB, b_0 , is processed first and the MSB, b_7 , is processed last.

6.6.2.4 BPSK modulation

The chip sequences are modulated onto the carrier using BPSK with raised cosine pulse shaping (roll-off factor = 1) where a chip value of one corresponds to a positive pulse and a chip value of zero corresponds to a negative pulse. The chip rate is 300 kchip/s for the 868/950 MHz band and 600 kchip/s in the 915 MHz band.

6.6.3 868/915/950 MHz band radio specification

6.6.3.1 Operating frequency range

The 868/915/950 MHz BPSK PHY operates in the 868.0–868.6 MHz frequency band, ~~and~~ in the 902–928 MHz frequency band ~~and~~ 950–956 MHz frequency band.

6.6.3.2 915/950 MHz band transmit PSD mask

The transmitted spectral products shall be less than the limits specified in Table 28. For the 915 MHz band, for both relative and absolute limits, average spectral power shall be measured using a 100 kHz resolution bandwidth. For the relative limit, the reference level shall be the highest average spectral power measured within ± 600 kHz of the carrier frequency.

Table 28—915/950 MHz band transmit PSD limits

Frequency band	Frequency	Relative limit	Absolute limit
915 MHz band	$ f - f_c > 1.2$ MHz	-20 dB	-20 dBm
950 MHz band (1 mW channels)	$ f - f_c > 0.5$ MHz	=	-39 dBm
	0.5 MHz $> f - f_c > 0.3$ MHz	=	-26 dBm/200 kHz
950 MHz band (10 mW channels)	$ f - f_c > 0.5$ MHz	=	-39 dBm
	0.5 MHz $> f - f_c > 0.3$ MHz	=	-18 dBm/200 kHz

6.6.3.3 Symbol rate

The symbol rate of an 868/915/950 MHz BPSK PHY conforming to this standard shall be 20 ksymbol/s when operating in the 868/950 MHz band and 40 ksymbol/s when operating in the 915 MHz band with an accuracy of ± 40 ppm.

NOTE—Current regulation for 950 MHz band PHY requires more stringent accuracy. Implementations need to comply with the current regulatory requirements.¹

6.6.3.5 Receiver jamming resistance

This subclause applies only to the 902–928 MHz band and to the 950–956 MHz band as there is only one channel available in the 868.0–868.6 MHz band.

The minimum jamming resistance levels are given in Table 29. For the 902–928 MHz band, the adjacent channel is one on either side of the desired channel that is closest in frequency to the desired channel, and the alternate channel is one more removed from the adjacent channel. For the 950–956 MHz band, the adjacent channel is one on either side of the desired channel that is closest in frequency to the desired channel, but has a distance of at least 0.6 MHz to the desired channel. The alternate channel is one more removed from the adjacent channel, but has a distance of at least 1.2 MHz to the desired channel. For example, when channel 5 is the desired channel, channel 4 and channel 6 are the adjacent channels, and channel 3 and channel 7 are the alternate channels.

Table 29—Minimum receiver jamming resistance requirements for 915/950 MHz BPSK PHY

Frequency band	Adjacent channel rejection	Alternate channel rejection
902–928 MHz band	0 dB	30 dB
950–956 MHz band	0 dB	24 dB

¹Notes in text, tables, and figures are given for information only and do not contain requirements needed to implement the standard.

The adjacent channel rejection shall be measured as follows: the desired signal shall be a compliant 915/950 MHz IEEE 802.15.4 BPSK PHY signal, as defined by 6.6.2, of pseudo-random data. The desired signal is input to the receiver at a level 3 dB above the maximum allowed receiver sensitivity given in 6.6.3.4.

In either the adjacent or the alternate channel, a compliant IEEE 802.15.4 BPSK PHY signal, as defined by 6.6.2, is input at the relative level specified in Table 29. The test shall be performed for only one interfering signal at a time. The receiver shall meet the error rate criteria defined in 6.1.7 under these conditions.

Insert after 6.6a the following new subclause:

6.6b 950 MHz band Gaussian frequency-shift keying (GFSK) PHY specifications

6.6b.1 950 MHz band data rates

The data rate of the 950 MHz band GFSK PHY shall be 100 kb/s when operating in the 950 MHz band.

6.6b.2 Modulation and spreading

The 950 MHz GFSK PHY does not employ any spreading technology. The bit sequence is modulated onto the carrier using GFSK.

6.6b.2.1 Reference modulator diagram

The functional block diagram in Figure 21c is provided as a reference for specifying the 950 MHz band GFSK PHY modulation and data whitening functions. The number in each block refers to the subclause that describes that function. Each bit in the PPDU shall be processed through the data whitening and modulation functions in octet-wise order, beginning with the preamble field and ending with the last octet of the PSDU. Within each octet, the LSB, b0, shall be processed first and the MSB, b7, shall be processed last.

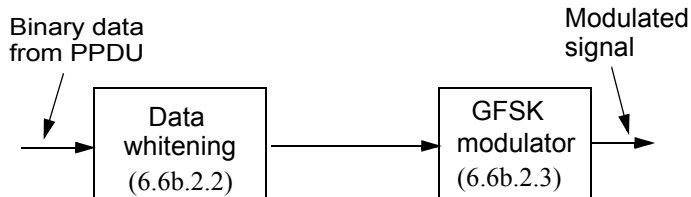

Figure 21c—Modulation and data whitening functions

6.6b.2.2 Data whitening

Data whitening shall be exclusive or (XOR) of PPDU data (without SHR) with the PN9 sequence. This shall be performed by the transmitter and is described by Equation (4b):

$$E_n = R_n \oplus \text{PN9}_n \quad (4b)$$

where

R_n is the raw data bit being whitened

E_n is the whitened bit

PN9_n is PN9 sequence

Index n starts after the SFD from 0 and is increased by one every symbol. For each packet transmitted, R_0 is the PHR first raw data bit after the SFD. Conversely, the decoding process, as performed at the receiver, can be described by Equation (4c):

$$R_n = RE_n \oplus PN9_n \quad (4c)$$

For each packet received, R_0 is the PHR first raw data bit. The PN generator is defined by the schematic in Figure 21d.

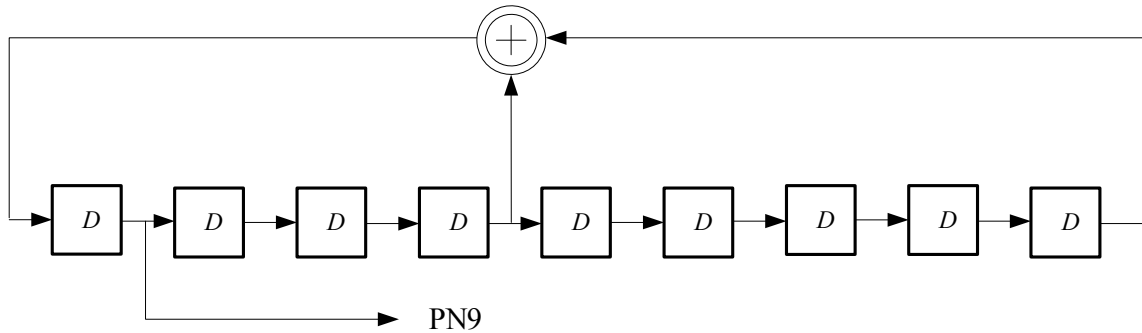

Figure 21d—Schematic of the PN generator

The seed in the PN9 shall be all ones: "11111111". The PN9 shall be reinitialized to the seed after each packet (either transmit or receive).

The preamble and the SFD are not whitened. After the SFD, the PN9 generator is clocked starting from the seed. For example, the first 30 bits out of the PN9, once it is enabled, would be as follows:

$PN9_n = 0_0, 0_1, 0_2, 0_3, 1_4, 1_5, 1_6, 1_7, 0_8, 1_9, 1_{10}, 1_{11}, 0_{12}, 0_{13}, 0_{14}, 0_{15}, 1_{16}, 0_{17}, 1_{18}, 1_{19}, 0_{20}, 0_{21}, 1_{22}, 1_{23}, 0_{24}, 1_{25}, 1_{26}, 0_{27}, 1_{28}, 1_{29}$

In the transmitter the bits after the SFD are obtained by an XOR function that has the PN9 at its first input and the data at its second input. The output of the XOR function is applied to the GFSK modulator.

In the receiver the bits after the SFD are obtained by an XOR function that has the PN9 at its first input and the received bits from the GFSK demodulator at its second input. The output of the XOR function is the received data.

6.6b.2.3 GFSK modulation

The bit sequences are modulated onto the carrier using GFSK with a modulation index of 1 where the Gaussian filter BT is 0.5, where a bit value of one is transmitted by shifting the frequency higher than the channel center and a bit value of zero is transmitted by shifting the frequency lower than the channel center. The bit rate is 100 kbit/s.

The nominal frequency deviation shall be 50 kHz. The deviation shall be between 70% and 130% of the nominal deviation. For the sequence 0101, the deviation shall be between 70% and 110% of the nominal deviation. For the sequence 00001111, the deviation shall be between 80% and 130% of the nominal deviation.

6.6b.3 950 MHz band radio specification for the GFSK PHY

6.6b.3.1 Operating frequency range

The 950 MHz GFSK PHY operates in 950.8–955.8 MHz frequency band.

6.6b.3.2 950 MHz band transmit PSD mask

The PSD mask for 950 MHz band GFSK PHY is specified such as below.

- The average power measured within ± 100 kHz of the frequency 300 kHz apart from the center frequency shall be -26 dBm or less for a 1 mW device or -18 dBm or less for a 10 mW device.
- The average power with 100 kHz resolution bandwidth in the frequency band from 950 MHz to 956 MHz except for the frequency band within ± 300 kHz of the carrier frequency f_c shall be -39 dBm.

NOTE—The PSD has to comply with Japanese regulations.

6.6b.3.3 Symbol rate

The 950 MHz GFSK PHY symbol rate shall be 100 ksymbol/s with an accuracy of ± 20 ppm.

6.6b.3.4 Receiver sensitivity

Under the conditions specified in 6.1.7, a compliant device shall be capable of achieving a sensitivity of -85 dBm or better.

6.6b.3.5 Receiver jamming resistance

The minimum jamming resistance levels are given in Table 29e. The adjacent channel is one on either side of the desired channel that is closest in frequency to the desired channel, and the alternate channel is one more removed from the adjacent channel. For example, when channel 15 is the desired channel, channel 14 and channel 16 are the adjacent channels, and channel 13 and channel 17 are the alternate channels.

Table 29e—Minimum receiver jamming resistance for 950 MHz GFSK PHY

Adjacent channel rejection	Alternate channel rejection
0 dB	24 dB

The adjacent channel rejection shall be measured as follows: the desired signal shall be a compliant 950 MHz IEEE 802.15.4 GFSK PHY signal, as defined by 6.6b.2 and 6.1.2.1d, of pseudo-random data. The desired signal is input to the receiver at a level 3 dB above the maximum allowed receiver sensitivity given in 6.6b.3.4.

In either the adjacent or the alternate channel, a compliant IEEE 802.15.4 GFSK PHY signal, as defined by 6.6b.2 and 6.1.2.1d, is input at the relative level specified in Table 29e. The test shall be performed for only one interfering signal at a time. The receiver shall meet the error rate criteria defined in 6.1.7 under these conditions.

6.9 General radio specifications

6.9.9 Clear channel assessment (CCA)

Insert the following new paragraph before the last paragraph of 6.9.9 as shown:

For the 950 MHz band, if channel 14 is supported CCA shall be performed on channel 13 and channel 14, if channel 17 is supported CCA shall be performed on channel 16 and channel 17 (English translation of ARIB STD-T96 [B1a]).

Change the last lettered list of 6.9.9 as indicated:

- a) The ED threshold shall correspond to a received signal power of at most 10 dB above the specified receiver sensitivity (see 6.5.3.3, 6.6.3.4, ~~6.6b.3.4~~, 6.7.3.4, and 6.8.3.4).
- b) The CCA detection time shall be equal to 8 symbol periods or *phyCCADuration* symbol periods for the 950 MHz band PHY.

7. MAC sublayer specification

7.1 MAC sublayer service specification

7.1.1 MAC data service

7.1.1.1 MCPS-DATA.request

7.1.1.1.3 Effect on receipt

Insert the following new paragraph before the second to last paragraph as shown:

If the MAC sublayer receives the request while transmission is prohibited it shall delay transmission until transmission is permitted.

7.4 MAC constants and PIB attributes

7.4.2 MAC PIB attributes

Insert the following new rows at the end of Table 26:

Table 86—MAC PIB attributes

Attribute	Identifier	Type	Range	Description	Default
<u>macTxControlActiveDuration</u>	<u>0x61</u>	<u>Integer</u>	<u>0–100000</u>	<u>The duration for which transmit is permitted without pause specified in symbols.</u>	<u>2000 for BPSK PHY and 10000 for GFSK PHY</u>
<u>macTxControlPauseDuration</u>	<u>0x62</u>	<u>Integer</u>	<u>2000 or 10000</u>	<u>The duration after transmission before another transmission is permitted specified in symbols.</u>	<u>2000 for BPSK PHY and 10000 for GFSK PHY</u>
<u>macTxTotalDuration</u>	<u>0x63</u>	<u>Integer</u>	<u>0x0–0xffffffff</u>	<u>The total transmit duration (including PHY header and FCS) specified in symbols. This can be read and cleared by NHL.</u>	<u>0</u>

7.5 MAC functional description

7.5.1 Channel access

7.5.1.4 CSMA-CA algorithm

Change the fourth paragraph of 7.5.1.4 as shown:

Each device shall maintain three variables for each transmission attempt: NB , CW and BE . NB is the number of times the CSMA-CA algorithm was required to backoff while attempting the current transmission; this value shall be initialized to zero before each new transmission attempt. CW is the contention window length, defining the number of backoff periods that need to be clear of channel activity before the transmission can commence. For Japanese 950 MHz operation, this value shall be initialized to one before each transmission attempt and reset to one each time the channel is assessed to be busy. Otherwise this value shall be initialized to two before each transmission attempt and reset to two each time the channel is assessed to be busy. The CW variable is only used for slotted CSMA-CA. BE is the backoff exponent, which is related to how many backoff periods a device shall wait before attempting to assess a channel. In unslotted systems, or slotted systems with the received BLE subfield (see Figure 47) set to zero, BE shall be initialized to the value of $macMinBE$. In slotted systems with the received BLE subfield set to one, this value shall be initialized to the lesser of two and the value of $macMinBE$. Note that if $macMinBE$ is set to zero, collision avoidance will be disabled during the first iteration of this algorithm.

Change the eighth and ninth paragraphs of 7.5.1.4 as shown:

In a slotted CSMA-CA system with the BLE subfield set to zero, the MAC sublayer shall ensure that, after the random backoff, the remaining CSMA-CA operations can be undertaken and the entire transaction can be transmitted before the end of the CAP. Note that any bit padding used by the supported PHY (see 6.7.2.2) must be considered in making this determination. If the number of backoff periods is greater than the remaining number of backoff periods in the CAP, the MAC sublayer shall pause the backoff countdown at the end of the CAP and resume it at the start of the CAP in the next superframe. If the number of backoff periods is less than or equal to the remaining number of backoff periods in the CAP, the MAC sublayer shall apply its backoff delay and then evaluate whether it can proceed. The MAC sublayer shall proceed if the remaining CSMA-CA algorithm steps (i.e., two CCA analyses or a single continuous CCA analysis of at least $phyCCADuration$ for the 950 MHz band in Japan, as described in Annex F and Annex K), the frame transmission, and any acknowledgment can be completed before the end of the CAP. If the MAC sublayer can proceed, it shall request that the PHY perform the CCA in the current superframe. If the MAC sublayer cannot proceed, it shall wait until the start of the CAP in the next superframe and apply a further random backoff delay [step (2)] before evaluating whether it can proceed again.

In a slotted CSMA-CA system with the BLE subfield set to one, the MAC sublayer shall ensure that, after the random backoff, the remaining CSMA-CA operations can be undertaken and the entire transaction can be transmitted before the end of the CAP. The backoff countdown shall only occur during the first $macBattLifeExtPeriods$ full backoff periods after the end of the IFS period following the beacon. The MAC sublayer shall proceed if the remaining CSMA-CA algorithm steps (two CCA analyses, or a single continuous CCA analysis of $phyCCADuration$ for the 950 MHz band in Japan, as described in Annex F and Annex K), the frame transmission, and any acknowledgment can be completed before the end of the CAP, and the frame transmission will start in one of the first $macBattLifeExtPeriods$ full backoff periods after the IFS period following the beacon. If the MAC sublayer can proceed, it shall request that the PHY perform the CCA in the current superframe. If the MAC sublayer cannot proceed, it shall wait until the start of the CAP in the next superframe and apply a further random backoff delay [step (2)] before evaluating whether it can proceed again.

7.5.2 Starting and maintaining PANs

7.5.2.4 Beacon generation

Insert the following new paragraph before the last paragraph of 7.5.2.4 as shown:

For devices operating in beacon-enabled mode in the Japanese 950 MHz band, a coordinator may precede beacon transmission with LBT without random backoff. The MAC shall ensure that the beacon is transmitted at the beginning of the superframe with accurate timing.

Annex D

(normative)

Protocol implementation conformance statement (PICS) proforma²

D.7 PICS proforma tables

D.7.2 Major capabilities for the PHY

D.7.2.1 PHY functions

Insert after the PLF13.4 row the following new row in Table D.2 (the entire table is not shown):

Table D.2—PHY functions

Item number	Item description	Reference	Status	Support		
				N/A	Yes	No
<u>PLF14</u>	<u>Support 950 MHz band PHY channels 14 and 17</u>	<u>6.1.2.1d</u>	<u>RF6.2:O</u>			

²Copyright release for PICS proformas: Users of this standard may freely reproduce the PICS proforma in this annex so that it can be used for its intended purpose and may further publish the completed PICS.

D.7.2.3 Radio frequency (RF)

Insert after the RF5.2 row the following new rows in Table D.4 and add a new note entry to the final row (the entire table is not shown):

Table D.4—Radio frequency (RF)

Item number	Item description	Reference	Status	Support		
				N/A	Yes	No
<u>RF6</u>	<u>950 MHz band PHYs</u>	<u>5.4.1, Clause 6, Table 1</u>	<u>O.3</u>			
<u>RF6.1</u>	<u>binary phase-shift keying (BPSK) PHY</u>	<u>6.6</u>	<u>RF6.1: O.7</u>			
<u>RF6.2</u>	<u>Gaussian Frequency-shift keying (GFSK) PHY</u>	<u>6.6b</u>	<u>RF6.1: O.7</u>			
<p><u>O.3 At least one of these features shall be supported.</u> <u>O.5 At least one of these features shall be supported.</u> <u>O.6 At least one of these features shall be supported.</u> <u>O.7 At least one of these features shall be supported.</u></p>						

Annex E

(informative)

Coexistence with other IEEE standards and proposed standards

E.1 Introduction

Insert the following new paragraph at the end of E.1:

The use of the 950 MHz band (950 MHz to 956 MHz) for LR-WPAN has only been recently allocated by the Japanese Regulatory committee. This is the first IEEE 802[®] standard defining use of the 950 MHz band (950 MHz to 956 MHz) in Japan and as such coexistence is not a practical issue at this time. However, the two PHYs specified for use in the 950 MHz band can potentially cause interference to each other. The Japanese regulation includes requirements to address coexistence for devices operating in band, e.g., Listen Before Talk, Transmission Control, and Duty Cycle restrictions. Together with the short duration (burst nature) of IEEE 802.15.4 packets and the use of CSMA-CA, coexistence is not considered to be a problem for the two PHYs when they share a common channel. Similar examples of this are shown in E.5.

Annex F

(informative)

Regulatory requirements

F.4 Applicable Japanese rules

Insert the following new subclause title (F.4.1) immediately following the clause title (F.4):

F.4.1 Applicable Japanese rules for 2.4 GHz band

Insert after F.4.1 the following new subclause:

F.4.2 Applicable Japanese rules for 950 MHz band

Following is a summary of the technical requirements of the Japanese rules for 950 MHz band specified in ARIB STD-T96 at the time of writing.

F.4.2.1 General conditions

- a) Communication method is one-way method, simplex method, duplex method, semi-duplex method, or broadcast.
- b) The contents of communications are primarily signals for telemeter, tele-control, and data transmission system.
- c) Modulation system is not specified.
- d) Operating frequency band: 950 MHz–956 MHz.
- e) Usage environment condition is not specified.

F.4.2.2 Transmitter

- a) Antenna power (at an antenna input) is limited to 1 mW or less. Exceptionally, it is allowed to be 10 mW or less for radio channels consisting of only unit radio channels (*1) that have center frequencies from 954.2 MHz to 954.8 MHz.

NOTE—(*1) Unit radio channels are defined that their center frequencies are located from 951.0 MHz to 955.6 MHz with 200 kHz separation and their bandwidth is 200 kHz.

- b) Tolerance of antenna power is between +20% (upper bound) and –80% (lower bound).
- c) Radio channel may consist of up to three consecutive unit radio channels.
- d) Frequency tolerance is ± 20 ppm.
- e) Modulation method is not specified.
- f) Occupied frequency bandwidth is $(200 \times n)$ kHz or less. (n is a number of unit radio channels constituting the radio channel and is an integer from 1 to 3.)
- g) Adjacent channel leakage power:
 - 1) Frequency band of signal in use is within more than 950 MHz and less than 956 MHz. (Antenna power is 1 mW or less.)
 - i) Spectral power at the edge of a radio channel is –20 dBm or less.
 - ii) Leakage power in unit radio channel adjacent to a radio channel is –26 dBm or less.

- 2) Frequency band of signal in use is within more than 954 MHz and less than 955 MHz. (Antenna power is 10 mW or less.)
- i) Spectral power at the edge of a radio channel is -10 dBm or less.
 - ii) Leakage power in unit radio channel adjacent to a radio channel is -18 dBm or less.
 - iii) It is desirable to comply with the conditions i) and ii) described in step 1) in consideration of an interference to the adjacent channels when antenna power is 1 mW or less.
- h) Spurious emission strength at the antenna input is less than the value in Table F.20.

Table F.20—Spurious emission strength (at antenna connector input)

Frequency band	Spurious emission strength (average power)	Reference bandwidth
$f \leq 1$ GHz (except for $710 \text{ MHz} < f \leq 960 \text{ MHz}$)	-36 dBm	100 kHz
$710 \text{ MHz} < f \leq 945 \text{ MHz}$	-55 dBm	1 MHz
$945 \text{ MHz} < f \leq 950 \text{ MHz}$	-55 dBm	100 kHz
$950 \text{ MHz} < f \leq 956 \text{ MHz}$ [except for $ f - f_c \leq 200 + 100 \times (n - 1)$ kHz]	-39 dBm	100 kHz
$956 \text{ MHz} < f \leq 958 \text{ MHz}$	-55 dBm	100 kHz
$958 \text{ MHz} < f \leq 960 \text{ MHz}$	-58 dBm	100 kHz
$1 \text{ GHz} < f$ (except for $1884.5 \text{ MHz} < f \leq 1919.6 \text{ MHz}$)	-30 dBm	1 MHz
$1884.5 \text{ MHz} < f \leq 1919.6 \text{ MHz}$	-55 dBm	1 MHz

F.4.2.3 Receiver

- a) Conducted spurious component is less than the value in Table F.21.

Table F.21—Conducted spurious component at receiver

Frequency band	Conducted spurious component (antenna input)	Reference bandwidth
$f \leq 1$ GHz (except for $710 \text{ MHz} < f \leq 960 \text{ MHz}$)	-54 dBm	100 kHz
$710 \text{ MHz} < f \leq 945 \text{ MHz}$	-55 dBm	1 MHz
$945 \text{ MHz} < f \leq 950 \text{ MHz}$	-55 dBm	100 kHz
$950 \text{ MHz} < f \leq 956 \text{ MHz}$ [except for $ f - f_c \leq 200 + 100 \times (n - 1)$ kHz]	-54 dBm	100 kHz
$956 \text{ MHz} < f \leq 958 \text{ MHz}$	-55 dBm	100 kHz

Table F.21—Conducted spurious component at receiver (continued)

Frequency band	Conducted spurious component (antenna input)	Reference bandwidth
958 MHz < $f \leq$ 960 MHz	−58 dBm	100 kHz
1 GHz < f (except for 1884.5 MHz < $f \leq$ 1919.6 MHz)	−47 dBm	1 MHz
1884.5 MHz < $f \leq$ 1919.6 MHz	−55 dBm	1 MHz

F.4.2.4 Controller

The controller has the following functions that comply with the conditions specified in this subclause:

- a) Sending control
 - 1) If the carrier sense time is 10 ms or more, the radio equipment stops its emission of radio signal within 1 s after it starts to emit. It waits 100 ms or more for the consecutive emission. However, it may emit again without waiting 100 ms, if it is within 1 s after its first emission and the emission is finished within this 1 s interval.
 - 2) If the carrier sense time is 128 μ s or more, the radio equipment stops its emission of radio signal within 100 ms after it starts to emit. It waits 100 ms or more for the consecutive emission. The amount of sending times summed for 1 h is 360 s or less. However, it may emit again without waiting 100 ms, if it is within 100 ms after its first emission and the emission is finished within this 100 ms interval.
 - 3) If no carrier sense is applied, the radio equipment stops its emission of radio signal within 100 ms after it starts to emit. It waits 100 ms or more for the consecutive emission. The amount of sending times summed for 1 hour is 3.6 s or less. However, it may emit again without waiting 100 ms, if it is within 100 ms after its first emission and the emission is finished within this 100 ms interval.
- b) Carrier sense (energy detection)
 - 1) Radio equipment checks interference existence by the carrier sense procedure before its new transmission.
 - 2) Carrier sense time is 128 μ s or more when the antenna power is 1 mW or less and 10 ms or more when the antenna power is more than 1 mW.
 - 3) Carrier sense level that is amount of received power at all of unit radio channels included in the radio channel to emit is −75 dBm at the antenna input. If the carrier sense level is not less than −75 dBm, radio equipment dose not do data transmission.
 - 4) Carrier sense is not necessary if the antenna power is 1 mW or less and the conditions of F.4.2.4 a) 3) are satisfied.
- c) Interference protection: Radio equipment has a function that can send or receive identification code.

Table F.22—Combinations of sending control parameters and carrier sense times

Antenna power	Carrier sense time	Limit of sending time	Pause time of sending	The amount of sending time summed for 1 hour
Less than 1 mW	More than 10 ms	Less than 1 s ^a	More than 100 ms	Don't care
	More than 128 μ s	Less than 100 ms ^b	More than 100 ms	Less than 360 s
	0	Less than 100 ms ^b	More than 100 ms	Less than 3.6 s
More than 1 mW and less than 10 mW	More than 10 ms	Less than 1 s ^a	More than 100 ms	Don't care

^aIt may emit again without waiting 100 ms, if it is within 1 s after its first emission and the emission is finished within this 1 s interval.

^bIt may emit again without waiting 100 ms, if it is within 100 ms after its first emission and the emission is finished within this 100 ms interval.

F.4.2.5 Chassis

It is structured not to be opened easily.

F.4.2.6 Telecommunication terminal equipment that uses the radio in itself

- a) It has an identification code that is 48 bits or more in length.
- b) Except for a particular case that is defined outside of the specification, it makes the decision if channel is used or not before using that channel. Only if that decision is “channel is not used,” it can set a communication path on its channel.

F.4.2.7 Antenna gain

Antenna gain is 3 dBi or less. However, in case EIRP is less than the value 3 dBi added by the maximum antenna power defined in F.4.2.2 a), it is allowed to compensate the difference by the antenna gain.

Annex G

(informative)

Bibliography

G.1 General

Insert the following bibliography in alphabetical order and renumber the remaining bibliographies:

[B1a] English translation of ARIB STD-T96, 950 MHz-Band Telemeter, Telecontrol and Data Transmission Radio Equipment for Specified Low Power Radio Station, 2008.6.6 (H20.6.6) Version 1.0.

G.2 Regulatory documents

Insert the following bibliography in alphanumerical order and renumber the remaining bibliographies:

[B22a] ARIB STD-T96, 950 MHz-Band Telemeter, Telecontrol and Data Transmission Radio Equipment for Specified Low Power Radio Station, 2008.6.6 (H20.6.6) Version 1.0.

Insert the a new annex as follows:

Annex K

(informative)

Considerations for 950 MHz band

This annex describes the way in which the IEEE 802.15.4 MAC may be configured and used to meet the requirements of the Japanese regulation for 950 MHz (see ARIB STD-T96 [B22a] and English translation of ARIB STD-T96 [B1a]).

The regulation requires that a device uses listen before talk (LBT) prior to transmission if the duty cycle of transmission exceeds 0.1%. There is also a requirement that a device does not continuously transmit. The maximum continuous transmission time and the duty cycle of transmission are dependent on the LBT duration. F.4.2.4 describes the detailed operation.

The regulation applies to a complete product. MAC PIB parameters are provided to permit a higher layer to control both the duty cycle and listen before talk functionality.

The PIB parameter *macTxTotalDuration* is provided to allow a higher layer to control the transmission duty cycle of operation. The value represents the total number of symbols transmitted since last set to 0. The higher layer may read the value at any time, and may set the value (typically to 0). This provides a mechanism for the higher layer to calculate the actual transmission time and hence the percentage transmission time over any arbitrary period.

The PIB parameters *macTxControlActiveDuration* and *macTxControlPauseDuration* permit a higher layer to control both the duration for which a device may transmit and the duration of the pause period, i.e., the time during which the MAC must pause to allow other devices access to the channel. These values are dependent on the transmission power and channel.